

Operation instruction



Version 3.0
2018-11
311-4283300-031

IMPORTANT SAFETY INSTRUCTIONS

Read Before Use

Dear owner of Acofar TD-4283 Blood Glucose Monitoring System,
The system consists of two main products: the meter and test strips. The control solution is not included. These products have been designed, tested, and proven to work together as a system to produce accurate blood glucose test results. Only use Acofar TD-4283 Test Strips and Acofar TD-4283 control solutions with the Acofar TD-4283 Blood Glucose Monitoring System.

Intended Use

This system is intended for external use (*in vitro* diagnostic use) only. It is used for the quantitative measurement of glucose in samples of fresh capillary whole blood taken from the finger, palm, forearm and upper arm. It is not intended to diagnose or screen for diabetes mellitus, or to be used on neonates.

It allows blood glucose levels to be measured by people with diabetes at home and by health care professionals in clinical settings as an aid to monitoring the effectiveness of diabetes control.

IMPORTANT SAFETY PRECAUTIONS

Professionals may test with capillary and venous blood sample; home use is limited to capillary whole blood testing.

This system provides you with plasma equivalent results and is displayed in milligrams of glucose per deciliter of blood (mg/dL).

APPEARANCE AND KEY FUNCTIONS OF THE METER

- 1 Main Button (M)
- 2 Display Screen
- 3 Test Strip Slot / Strip Port Comm
- 4 Battery Compartment

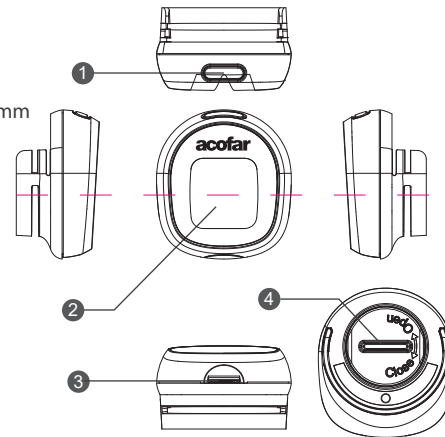

Note:

The meter will turn off automatically after 180 seconds without any action or you can press and hold the M for 3 seconds to turn off the meter.

METER DISPLAY

- 1 Test Result / Measuring Mode
- 2 Blood Drop Symbol
- 3 Measurement Unit

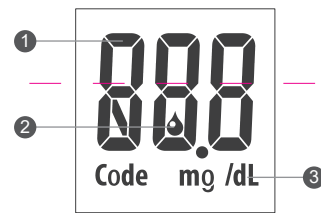

ACOFAR TD-4283 TEST STRIPS

Your system measures the amount of sugar (glucose) in whole blood. Blood is applied to the absorbent hole on the test strip and is automatically drawn into the reaction cell where the reaction takes place.

The test strip consists of the following parts:

- Absorbent Hole**
Apply a drop of blood here. The blood will be automatically absorbed.
- Confirmation Window**
This is where you confirm if enough blood has been applied to the absorbent hole in the strip.
- Test Strip Handle**
Hold this part to insert the test strip into the slot.
- Contact Bars**
Insert this end of the test strip into the meter. Push it in firmly until it will go no further.

THE TWO MEASURING MODES

The meter provides you with TWO modes for measuring, General and QC.

Modes	Use when
General (no show)	Any time of day without regard to time since last meal
QC (show C)	Testing with the control solution

You can switch between each mode by:

1. Start with the meter switched off. Insert a test strip to turn on the meter. The screen will display: CH and then "↓".
2. Press M to switch between General and QC mode.

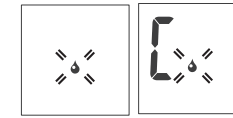
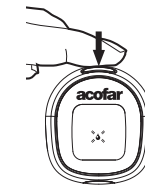

TESTING YOUR BLOOD

Preparing the Lancing Device for Blood Testing

Please follow the instructions in the lancing device insert for collecting a blood sample.

- Step 1. Insert the test strip to turn on the meter**
Wait for the meter to display the ↓.

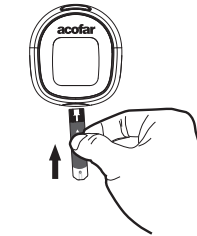

- Step 2. Select the appropriate measuring mode by pressing M**

For selecting the measurement mode, please refer to the "TWO MEASURING MODES"

- Step 3. Apply blood sample**

Obtain a drop of blood of at least 0.5 µL using a lancing device. Use the clear cap for sites other than fingers and refer to the strip package insert for more details.

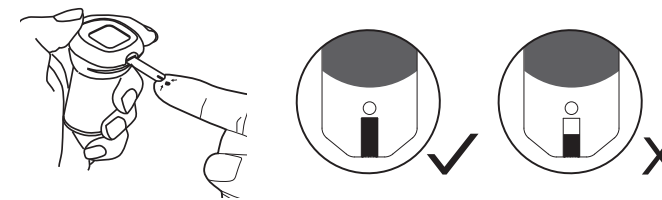

Gently apply the drop of blood to the absorbent hole of the test strip at a tilted angle. Confirmation window should be completely filled if enough blood sample has been applied. Do NOT remove your finger until the meter begins to count down.

If the confirmation window is not filled completely before the meter begins to count down, do not add more blood to the test strip. Discard the test strip and start again. If you have trouble filling the test strip, please call the customer service of Acofarma, 902 36 22 03.

Note:

If you do not apply a blood sample to the test strip within 3 minutes, the meter will turn itself off. You must remove the strip and insert it back into the meter to restart the test.

- Step 4. Get result**

The blood glucose result will be stored in the memory automatically.

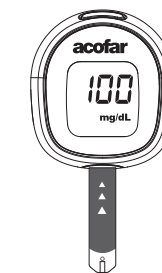

Warning:

1. Please do not change your treatment based on the result without first consulting your health care professional.
2. Turn the meter off by removing the test strip. Discard the used test strip and lancet carefully according to your local regulations.

ALTERNATIVE SITE TESTING (AST)

You can test on a variety of locations on your body. **Important: There are limitations with AST (Alternative Site Testing). Please consult your health care professional before you perform AST.**

When to use AST?

Food, medication, illness, stress and exercise can affect blood glucose levels. Capillary blood at the fingertip reflects these changes faster than capillary blood at other sites. Thus, when testing blood glucose during or immediately after a meal, physical exercise, or any other event, take a blood sample from your finger only.

We strongly recommend that you perform AST ONLY at the following times:

- In a pre-meal or fasting state (more than 2 hours since the last meal).
- Two hours or more after taking insulin.
- Two hours or more after exercise.

Do NOT use AST if:

- You think your blood glucose is low.
- You are unaware of hypoglycemia
- You are testing for hyperglycemia
- Your AST results do not match the way you feel.
- Your routine glucose results often fluctuate.

VIEWING THE METER MEMORY

Viewing Results

Your Meter stores the 150 most recent blood glucose test results in its memory. You can review the test results with these easy steps.

- Step 1. Enter the memory mode**

With the meter turned off, press M twice. The first test result will appear, indicating that you are in the memory mode.



- Step 2. Empty memory**

When using the meter for the first time or if the results have been deleted, "---" will appear, indicating that there are no test results in the memory.

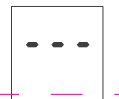

- Step 3. Recall test results**

If you continue to press M, you can then review the last 150 tests in the memory.

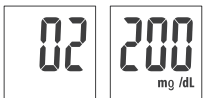

- Step 4. Exit the memory mode**

After displaying the last test result in memory, press the M again. The meter displays "End" and then turns off.



Note:

- If you wish to exit memory mode before the last result being displayed, press the M for 3 seconds.
- When the memory is full, the oldest test result will be replaced by the newest test result.
- The control solution results are NOT stored in the memory. Only blood glucose results will be stored.

DOWNLOADING RESULTS ONTO A COMPUTER

You can use the meter with a strip port cable and the Health Care Software System to view test results on your personal computer. To learn more about the Health Care Software System or to obtain a strip port cable separately, please contact the customer service of Acofarma, 902 36 22 03.

- 1. Obtaining the required cable and installing the software**

To download the Health Care Software System, please visit the TaiDoc's website at <http://www.taidoc.com>

- 2. Connecting to a personal computer**

Connect the strip port cable to a cable port on your computer. With the meter switched off, insert the other end of the strip port cable to the meter data port. "PC" will appear on the meter display, indicating that the meter is in communication mode.

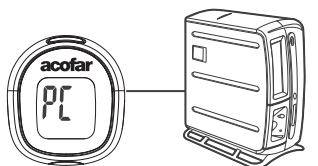

Warranty certificate

Year warranty

Owner's portion:

Name of product: _____

Name of owner: _____

Address: _____

Tel No: (Mobile) _____ (H) _____ (O) _____

Email: _____ Age: _____ Gender: M F

Date of Purchase / /
day / month / year

Dealer's Stamp:

Serial No.: _____

* Note: Please produce this card together with the purchase receipt for warranty service.

Warranty registration card

Dealer's portion:

Name of product: _____

Name of owner: _____

Address: _____

Tel No: (Mobile) _____ (H) _____ (O) _____

Email: _____ Age: _____ Gender: M F

Date of purchase: / /
day / month / year

Dealer's Stamp:

Serial No.: _____

* Important: to qualify for the warranty, please fill in this card and mail to Acofarma - marketing department - within 14 days from the date of purchase.

3. Data transmission

To transmit data, follow the instructions provided with the software. Results will be transmitted with date and time. Remove the cable and the meter will automatically switch off.

Warning:

While the meter is connecting to the PC, it will be unable to perform a blood glucose test.

BATTERY

Your meter comes with one 3V CR2032 lithium battery. If the low battery symbol "Lo" appears on the screen indicating that the battery is low and it is time to change the battery.

E-b error appears:

The power is not enough to do a test. Please change the battery immediately.



Replacing the Battery

To replace the battery, make sure that the meter is turned off.

1. Open the battery cover by a direction anti-clockwise and lift it up to remove.
2. Remove the old battery and replace with one new 3V CR2032 lithium battery.
3. Close the battery cover. Make sure the battery is inserted correctly.

Note:

- Replacing the battery does not affect the test results stored in the memory.
- As with all small batteries, these batteries should be kept away from children. If swallowed, promptly seek medical assistance.
- Battery might leak chemicals if unused for a long time. Remove the battery if you are not going to use the device for an extended period (i.e., 3 months or more).
- Properly dispose of the battery according to your local environmental regulations.

MAINTENANCE

Caring for Your Meter

Cleaning

1. To clean the meter exterior, wipe it with a cloth moistened with tap water or a mild cleaning agent, then dry the device with a soft dry cloth. Do NOT rinse with water.
2. Do NOT use organic solvents to clean the meter.

Meter Storage

- Storage conditions: -4°F to 140°F (-20°C to 60°C), below 95% relative humidity.
- Always store or transport the meter in its original storage case.
- Avoid dropping and heavy impact.
- Avoid direct sunlight and high humidity.

Meter Disposal

The used meter should be treated as contaminated that may carry a risk of infection during measurement. The batteries in this used meter should be removed and the meter should be disposed in accordance with local regulations.

The meter falls outside the scope of the European Directive 2002/96/EC-Directive on waste electrical and electronic equipment (WEEE).

Strip Vial Embedding and Replacement

1. When you use the meter first time, the meter is designed to embed into the cap of strip vial at an angle upward. If the meter is embedded well, you will hear a "click" afterwards.

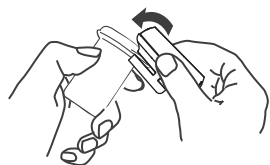

2. Open the cap of strip vial to take out a new strip for blood testing.



3. After using up all the strips, detach the meter from the strip vial at an angle downward, dispose the empty strip vial. Replace with a new strip vial.

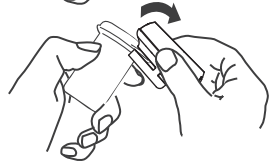

CHECKING THE SYSTEM WITH CONTROL SOLUTIONS

Our Control Solution contains a known amount of glucose that reacts with test strips. By comparing the result of your control solution test with the expected range printed on the test strip vial label, you can check that the meter and the test strips are working together as a system and that you are performing the test correctly. It is very important that you perform this simple check routinely to make sure you get accurate results.

HOW TO PERFORM A CONTROL SOLUTION TEST

Step 1. Insert test strip

Insert a test strip into the test slot with the contact bars end first and facing up.

(Contact bars must be inserted all the way into the meter or you may get an inaccurate test result.) The meter turns on automatically and displays the following in sequence: CH and then "0"

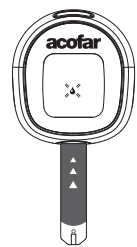

When the "0" symbol appears on the display, press M and "C" will appear on the display. When the "C" sign is displayed, the meter will not store your test result in memory under "QC". If you decide not to perform a control solution test, press M again and the "C" sign will disappear.



Control solution is not included in this kit.

Caution:

Every time you perform a control solution test, you have to mark it so that the test result will NOT be stored in the memory. Failure to do so will mix up the blood glucose test results with the control solution test results in memory.

Step 2. Apply Control Solution

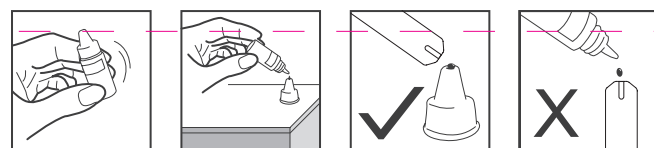

Shake the control solution vial thoroughly before use. Squeeze out the first drop and wipe it off, then squeeze out another drop and place it on the tip of the vial cap. Hold the meter to move the absorbent hole of the test strip to touch the drop. Once the confirmation window fills completely, the meter will begin counting down. To avoid contaminating the control solution, do not directly apply control solution onto a strip.

Step 3. Read and compare the results

After the meter counts to 0, the result of the control solution test will appear. Compare the result with range printed on the test strip vial. The result should fall within this range.

Out-of-range results

If you continue to have test results fall outside the range printed on the test strip vial, the meter and strips may not be working properly. Do NOT test your blood. Contact the customer service of Acofarma, 902 36 22 03.

DISPLAY MESSAGES AND PROBLEM-SOLVING GUIDE

The following is a summary of display messages. If your meter displays an error message, please follow the actions for the error message as described in the table below. If the problem persists, please contact the customer service of Acofarma, 902 36 22 03.

Message	What it means
Lo	< 20 mg/dL (1.1 mmol/L)
Hi	>650 mg/dL (36.1 mmol/L)

Message	What it means	What to do
E-b	Appears when the battery is too low.	Replace the batteries immediately.
E-U	Appears when a used test strip is inserted.	Repeat with a new test strip.
E-t	Appears when ambient temperature is above or below system operation range.	System operation range is 10°C to 40°C (50°F to 104°F). Repeat the test after the meter and test strip are in the above temperature range.
E-0	Problems with the meter.	Repeat the test with a new test strip. If the meter still does not work, please contact the customer service of Acofarma, 902 36 22 03.
E-R		
E-E		
E-C		
E-f	Appears when test strip is removed while counting down, or insufficient blood volume.	Review the instructions and repeat test with a new strip. If the problem persists, please contact the customer service of Acofarma, 902 36 22 03.

SYMBOL INFORMATION

Symbol	Referent
IVD	In vitro diagnostic medical device
i	Consult instructions for use
⚡	Temperature limitation
🕒	Use by / Expiry date
LOT	Batch code
🏭	Manufacturer
SN	Serial number
EC REP	Authorized representative in the European Community
⚠️	Caution, consult accompanying documents
CE 0123	CE mark
🌫️	Humidity limitation
♻️	Collection for electrical and electronic equipment

SPECIFICATIONS

Model No.: TD-4283
 Dimension & Weight: 43.5 (L) x 39.3 (W) x 24.2 (H) mm
 Weight: 18 g (include battery)
 Power Source: one 3V CR2032 lithium battery (for at least 500 measurements)
 Display: LCD
 Memory: 150 memory sets
 External Output: strip port cable communication (not included)

Automatic detection of electrode insertion
 Auto sample loading detection
 Automatic reaction time count-down
 Auto switch-off after 3 minutes without action
 Temperature warning

Operating Condition:
 10°C to 40°C (50°F to 104°F), below 85% R.H.
 Meter Storage/ Transportation Conditions:
 -20°C to 60°C (-4°F to 140°F), below 95% R.H.
 Strip Storage/ Transportation conditions:
 2°C to 30°C (35.6°F to 86°F), below 85% R.H.
 Measurement Units: fixed mg/dL
 Measurement Range: 20 ~ 650 mg/dL (1.1-36.1 mmol/L)
 Expected service life: 5 years

This device has been tested to meet the electrical and safety requirements of:
 IEC/EN 61010-1, IEC/EN 61010-2-101, EN 61326-1, IEC/EN 61326-2-6.

Distributed by:

acofarma

DOMICILIO SOCIAL:
 Acofarma Distribución, S.A.
 C/ Poeta Joan Maragall, 56, 2^aE
 28020 Madrid
 Pol. Sta. Margarita. C/ Llobregat, 20
 08223 Terrassa - Barcelona
 Atención al consumidor 910 762 111 / 937 360 080 - www.acofarma.es

TaiDoc Technology Corporation
 B1-7F, No. 127, Wugong 2nd Rd., Wugu Dist.,
 24888 New Taipei City, Taiwan
 www.taidoc.com

EC REP MedNet GmbH
 Borkstraße 10, 48163 Münster, Germany



For self-testing

TERMS & CONDITIONS OF WARRANTY

1. We warrant this product to be free of defects in workmanship and materials within the said warranty period on the warranty certificate.
2. During the warranty period, if this product is found to be defective, you may bring it, together with the purchase receipt and Warranty Certificate, on a carry-in basis to our office during normal business hours for warranty service. We will then repair or replace defective parts or exchanging the whole product as we may choose, at no charge to the original owner. After such repair, replacement or exchange, the product will be warranted for up to the remainder of the warranty period.
3. This warranty is valid only if the Warranty Certificate and Warranty Registration Card are duly completed with date of purchase, serial number and dealer's stamp, and if the Warranty Registration Card is sent to our office not later than 14 days from the date of purchase.
4. This warranty is void if this product has been repaired or serviced by unauthorized person. This warranty does not cover defects caused by misuse, abuse, accident, tampering, lack of reasonable care, fire or any other acts beyond human control.
5. Except as stated in the above paragraphs, we disclaim all other warranties, implied or expressed, including the warranties of merchantability or fitness for a particular purpose with respect to the use of this product. We shall not be liable for any direct, consequential or incidental damages arising out of the use or inability to use this product.

Please affix stamp

Dealer's information